

Kräus[®]

INSTALLATION GUIDE

Allyn™ Pull Down Kitchen Faucet

KPF-4101

Congratulations on the purchase of your new Kraus® plumbing fixture!

Please keep the box and packaging materials until your product is completely installed. If you have any questions, require technical assistance, or have any problems with your product:



DO NOT RETURN TO STORE

Please contact our Customer Service Team

1-800-775-0703 / customerservice@kraususa.com

Have the model number available, and retain a copy of your receipt with purchase date for reference.

If for any reason this product does not meet your expectations, please be sure to repack this product in the original box and packaging material to avoid damage during transit.



Prior to Installation:

- Make sure you have all necessary parts by checking the diagram and parts list. If any part is missing or damaged, please contact Kraus® Customer Service at 800-775-0703 for a replacement
- Read all instructions and safety warnings and ensure you have all tools, parts, and equipment necessary for a safe installation.
- Turn off the hot and cold water lines at the angle stops and turn on the old faucet to release any built-up pressure
- Pre-drilled countertop hole size requirement: 1-3/8" (min)
- Max countertop thickness: 3-1/2"

Tools you will need:

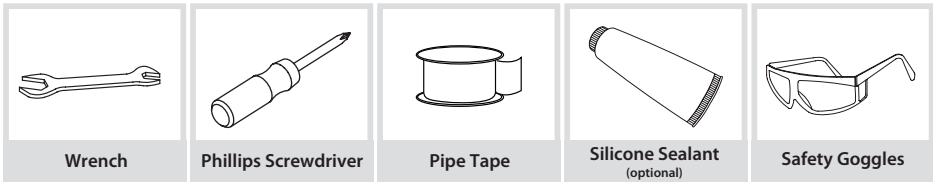

Care & Maintenance

- * To keep the product clean & shining, follow the steps below:
1. Rinse with clean water & dry with a soft cloth
 2. Do not clean with soaps, acid, polish, abrasives or harsh cleaners
 3. Do not use cloth with a coarse surface
 4. Unscrew the aerator and clean when necessary
- * This installation manual is subject to change without further notice.



Diagram and Parts List

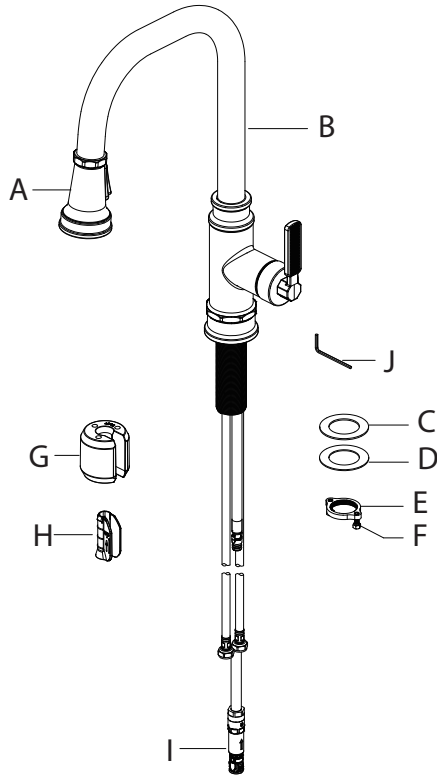

A. Spray Head
B. Faucet Body
C. Rubber Washer
D. Metal Washer
E. Mounting Nut
F. Screws

G. Weight
H. Weight Clip
I. Quick Connector
J. Hex Wrench

Faucet Dimension

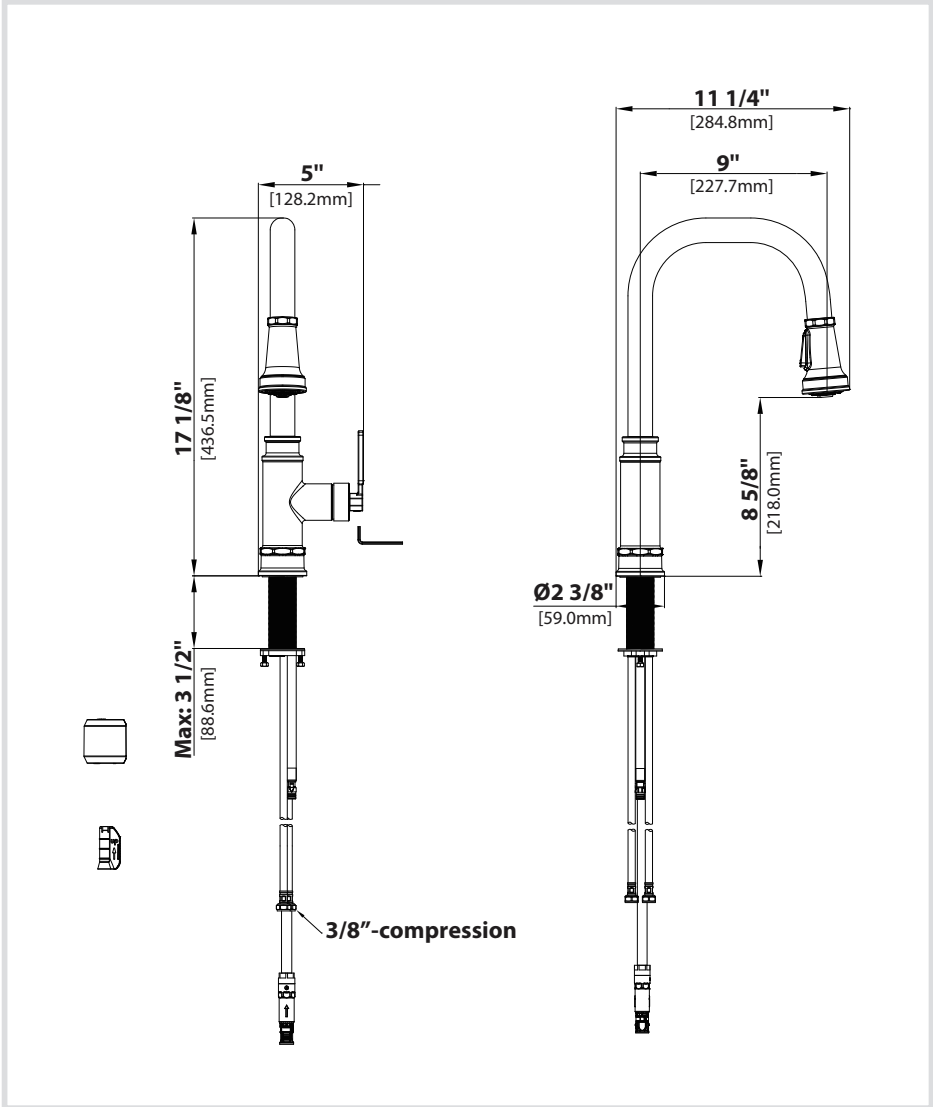

Installer Tip:

Shut off main water supply before installing new faucet

Step 1: Installing the faucet

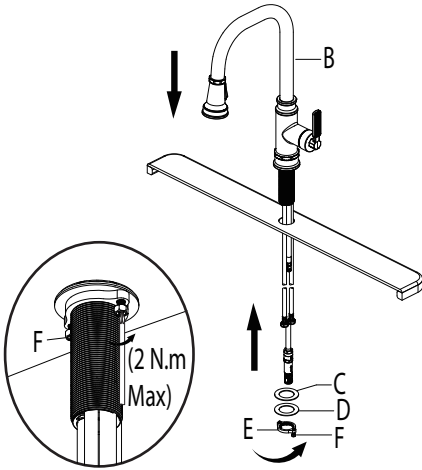

Shut off the water supply. Place faucet (B) through the hole in countertop. Secure the faucet (B) to the countertop using the rubber washer (C), metal washer (D) and mounting nut (E) provided. Hand tighten the nut (E) onto the faucet assembly. Lock the nut (E) into position by tightening the screws (F) with a phillips screwdriver.

Step 2: Securing the faucet assembly

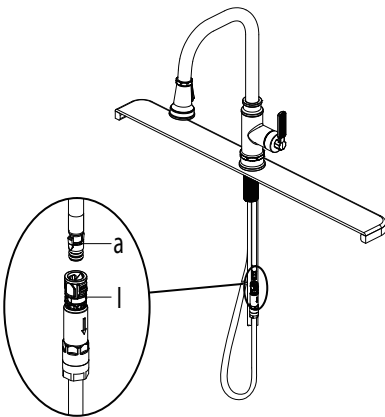

Push the quick connector (I) firmly upward and attach it to the receiving block (a). Pull down moderately to ensure the connection has been made.

Step 3: Securing the faucet assembly

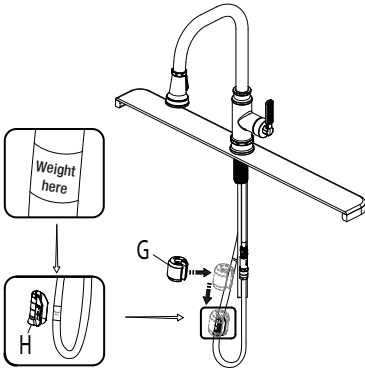

Install the weight clip (H) at the point of the hose marking "weight here". Insert the weight (G) onto the weight clip (H) by sliding it down onto the weight clip (H).

Step 4: Connect waterlines to main valve

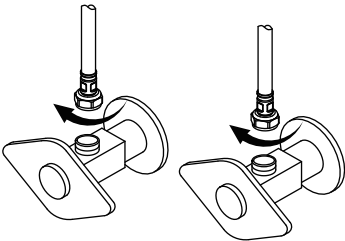

Attach waterlines to angle stops and tighten until snug. Turn on angles stops and check for leaks (DO NOT TURN FAUCET ON)

NOTE: Please make sure filter washers are installed before connecting to the main valve.

Step 5: Flush faucet

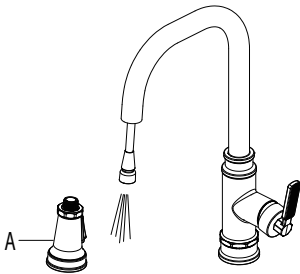

NOTE: Please make sure washer is installed attaching spray head to hose.

Pull the hose assembly out of the spout and remove the spray head (A) by unscrewing it from the hose in a counterclockwise direction. Be sure to hold the end of the hose down into the sink and turn the faucet on to the warm position where it mixes hot and cold water. Flush the water lines for one minute. This flushes away any debris that could cause damage to internal parts. Check for leaks. Re-tighten any connections if necessary, but do not overtighten. Reinstall the spray head (A) by hand tightening it back onto the spray hose. After installation is completed, turn on the hot and cold water supplies. Check for leaks.

Replacement Parts

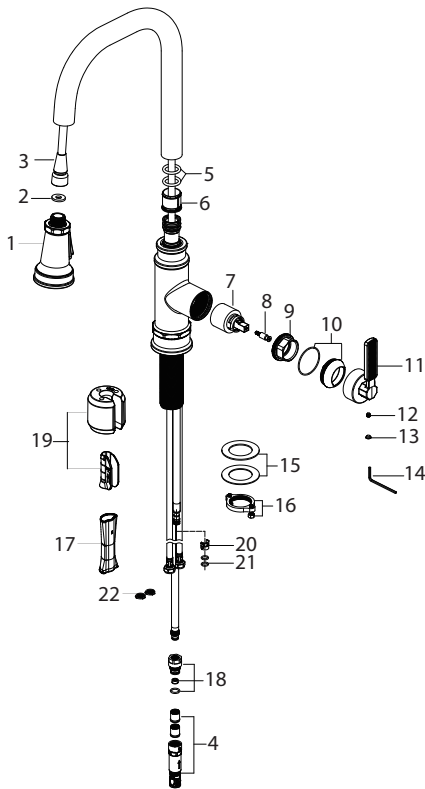

Replacement Parts List	Finish / Color	Part #
1. Spray Head	CH, MB, SFACB, SFSB, SFS*	KP27298
2. Sprayer Washer		KP27208
3. Sprayer Hose	GRCH, GRSFS, BLMB, BLSFSB, BLSFACB*	KP27209
4. Quick connector assembly		KP27090
5. O-Ring		KP27210
6. Inverter		KP27211
7. Cartridge		KP27257
8. Screw		KP27299
9. Bonnet Nut		KP27300
10. Cap & O-ring	CH, MB, SFACB, SFSB, SFS*	KP27301
11. Handle	CH, MB, SFACB, SFSB, SFS, SFSMB, SFSCH*	KP27302
12. Set Screw		KP27001
13. Cover button	BL, GR*	KP27194
14. Hex wrench		KP27020
15. Rubber & metal washer		KP27028
16. Mounting Nut & Screw		KP27079
17. Inverter		KP27123
18. 1.8GPM Flow Restrictor		KP27074
19. Weight & Clip Assembly		KP27212
20. Block		KP27073
21. O-Ring		KP27092
22. Filter Washer		KP27167

*Denotes faucet component color options:

Black hose with Spot Free Black Stainless connector (BLSFSB);
 Gray hose with Chrome connector (GRCH); Gray hose with Spot-Free Stainless connector (GRSFS);
 Black hose w/ Matte Black connector (BLMB); Black hose with Spot-Free Antique Champagne Bronze (BLSFACB);
 SFSB - Spot Free Black Stainless; SFS - Spot Free Stainless; CH - Chrome; MB - Matte Black;
 SFSMB - Spot Free Stainless+Matte Black; SFSCH - Spot Free Stainless+Chrome;
 SFACB - Spot Free Antique Champagne Bronze; GR - Grey; BL - Black

Troubleshooting

If you have followed the instructions carefully and your faucet still does not work properly, take the following corrective steps:

PROBLEM	CAUSE	ACTION
Leakage under the handle	Bonnet nut (9) has come loose	Remove the cover button (13). Loosen set screw (12) with hex wrench (14). Remove the handle (11). Unscrew cap (10) (by hand only). Tighten bonnet nut (9) with an adjustable wrench
The aerator has an irregular or reduced water flow	The aerator is dirty or mis-fitted	Remove the aerator and check for debris. Ensure that the rubber washer is properly installed.
Water will not shut off completely	Cartridge may need to be adjusted or replaced	Remove the cover button (13). Loosen set screw (12) with hex wrench (14). Remove the handle (11). Unscrew cap (10) (by hand only). Tighten bonnet nut (9) with an adjustable wrench. Remove the cartridge (8). Check for cracks
There is leaking from the sink drain at the base of the sink.	The sink has a rough or irregular surface.	Apply additional silicone sealant to the beveled side of the drain flange. Retighten and test for leaks
There is a low flow of water.	The filter washer in the hose connectors is dirty.	Turn off the water supply at water valve and unscrew the hose connectors from water supply lines. Clean the filter washer in the water lines with hot water, removing any debris or calcium build up

Codes/Standards Applicable:



NSF / ANSI 61



ASME A112.18.1
1.8GPM 6.8L/min maximum

Faucet - Lifetime Limited Warranty

Kraus®USA Plumbing, LLC ("Kraus") extends this warranty to the original purchaser for personal household use of the Faucet when purchased from an authorized Kraus dealer and in the location of original installation. This warranty is non-transferable.

Kraus warrants the structure and finish of the Faucet to be free from defects in material and workmanship under normal usage for as long as the original purchaser resides in the residence in which the Faucet was first installed.

Kraus warrants the Faucet's sprayhead assembly (including the engine, aerators, structure, restrictors, back flow preventers, sprayer hoses, braided supply line hoses which encompasses nylon, silicon and stainless steel) of the product to be free from defects in material and workmanship under normal usage for a period of one (1) year from the date of purchase.

Kraus warrants the Faucet's cartridge to be free from defects in material and workmanship under normal usage for a period of five (5) years from the date of purchase.

Any product reported to the authorized dealer or to Kraus as being defective within the warranty period will be repaired or replaced with a product of equal value at the option of Kraus.

Commercial Warranty

Kraus USA Plumbing, LLC ("Kraus") warrants its Products for a period of one (1) year to commercial purchasers of Products used in industrial, commercial and business applications.

Care and Cleaning Instructions

Certain cleaning products may cause damage to a Product's finish and use of the following on the Product will void this warranty:

- Abrasive cleaners such as powders, bleach, ammonia, alcohol or chlorine
- Abrasive pads, steel wool or wire brushes

What is Not Covered

This warranty does not cover Products that were discontinued when purchased or display Products, whether such Products were purchased at discount outlets, unauthorized dealers, and/or sold on clearance. This warranty does not cover any free gifts included with purchase.

This warranty does not cover damage resulting from neglect, misuse (including use for an unintended application), abuse, carelessness, accident, hard water or mineral deposits, exposure to corrosive materials, improper maintenance, alteration of the Product, or failure to follow care, cleaning or installation instructions enclosed with your Product. Kraus recommends that all Kraus Products be installed by a fully licensed and insured trade professional with experience in the installation of bathroom and/or kitchen manufactured goods.

How to Make a Warranty Claim

If you are a **consumer purchaser**, please contact a Kraus® Customer Service Representative at:

Kraus USA Plumbing, LLC
12 Harbor Park Drive
Port Washington, NY 11050
Toll-free 800-775-0703
Customerservice@kraususa.com

If you are a **plumbing contractor or trade professional**, please contact a Kraus Pro Representative at:

Kraus USA Plumbing, LLC
12 Harbor Park Drive
Port Washington, NY 11050
516-801-8955
Proservice@kraususa.com

If you are an **authorized partner**, please contact a Partner Support Representative at:

Kraus USA Plumbing, LLC
12 Harbor Park Drive
Port Washington, NY 11050
516-801-8954
Partnersupport@kraususa.com

In requesting warranty service, please be ready to provide your proof of purchase and a description of the problem. Shipping charges will be covered for the first (1) year of the warranted replacement part or product (HI, AK, and Puerto Rico shipping charges may apply). International shipping fees are not included.

Limitation on Duration of Implied Warranties

Please note that some states/provinces (including Quebec) do not allow limitations on how long an implied warranty lasts, so the below limitations may not apply to you. TO THE MAXIMUM EXTENT PERMITTED BY APPLICABLE LAW, ANY IMPLIED WARRANTY, INCLUDING THE IMPLIED WARRANTIES OF MERCHANTABILITY AND OF FITNESS FOR A PARTICULAR PURPOSE, IS LIMITED TO THE STATUTORY PERIOD OR THE DURATION OF THIS WARRANTY, WHICHEVER IS SHORTER.

Limitation of Special, Incidental or Consequential Damages

Please note that some states/provinces (including Quebec) do not allow the exclusion or limitation of special, incidental or consequential damages, so the below limitations and exclusions may not apply to you. TO THE MAXIMUM EXTENT PERMITTED BY APPLICABLE LAW, THIS WARRANTY DOES NOT COVER, AND KRAUS USA PLUMBING, LLC SHALL NOT BE LIABLE FOR, ANY SPECIAL, INCIDENTAL OR CONSEQUENTIAL DAMAGES (INCLUDING LABOR CHARGES TO REPAIR, REPLACE, INSTALL OR REMOVE THIS PRODUCT), WHETHER ARISING OUT OF BREACH OF ANY EXPRESS OR IMPLIED WARRANTY, BREACH OF CONTRACT, TORT, OR OTHERWISE.

This warranty gives you specific legal rights, and you may also have other rights which vary from state/province to state/province.

Download the Kraus Care & Maintenance Guide at:
<http://www.kraususa.com/maintenance>

IMPORTANT

Register Your Kraus Product

Activate Your Warranty

Access Premium Customer Support

Get Product Information

REGISTER TODAY

<http://www.kraususa.com/registration>



Kräus[®]
www.kraususa.com