



## 2x4 In-Wall Tank & Carrier System K-18829

### Features

- Robust steel tube frame.
- Insulated tank to prevent sweating.
- Large flush actuator plate opening can be removed for easy access to the inner tank.
- Adjustable height allowing the bowl to be set anywhere from 15-3/8 inches to 28-1/2 inches from floor.
- Dual flush actuator offers a choice of 0.8 or 1.6 gallons per flush (gpf).
- Works with K-6299 or K-6918 bowls and K-4177, K-8857, K-75891, K-5413, K-75890, or K-77271 flush actuator plates to create a complete solution.

### Technology

- Dual-flush technology allows you to choose between a full- or partial-flush.

### Installation

- Durable steel frame carrier is installed on 2"x4" studs behind the wall. See installation guide for more detailed information.
- When installed per Kohler's installation instructions, the Kohler in-wall tank and carrier system can support up to 880 lbs without damage.
- Supply line not included.

### Water Conservation & Rebates

- WaterSense® toilets meet strict EPA flushing guidelines, including using at least 20 percent less water than 1.6-gallon toilets.
- Eligible for consumer rebates in some municipalities.

### Recommended Products/Accessories

K-6299 wall-hung elongated dual-flush toilet  
K-4177 Flush Actuator Plate  
K-8857 Flush Actuator Plate  
K-5413 Flush Actuator Plate  
K-75890 Flush Actuator Plate  
K-75891 Flush Actuator Plate

### Included Components

Product consists of:

K-18829 2x4 In-Wall Tank & Carrier System



### Codes/Standards

ASME A112.6.2  
ASME A112.19.14

### KOHLER® One-Year Limited Warranty

See website for detailed warranty information.

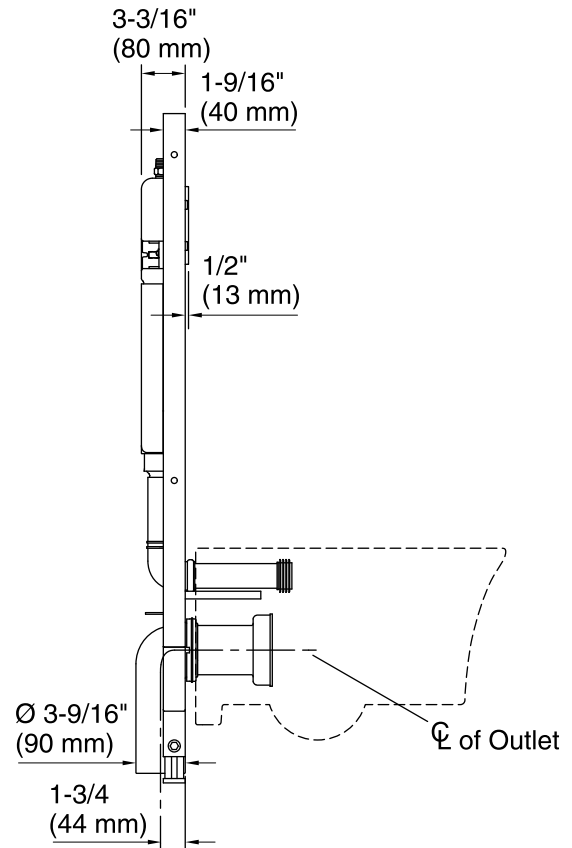
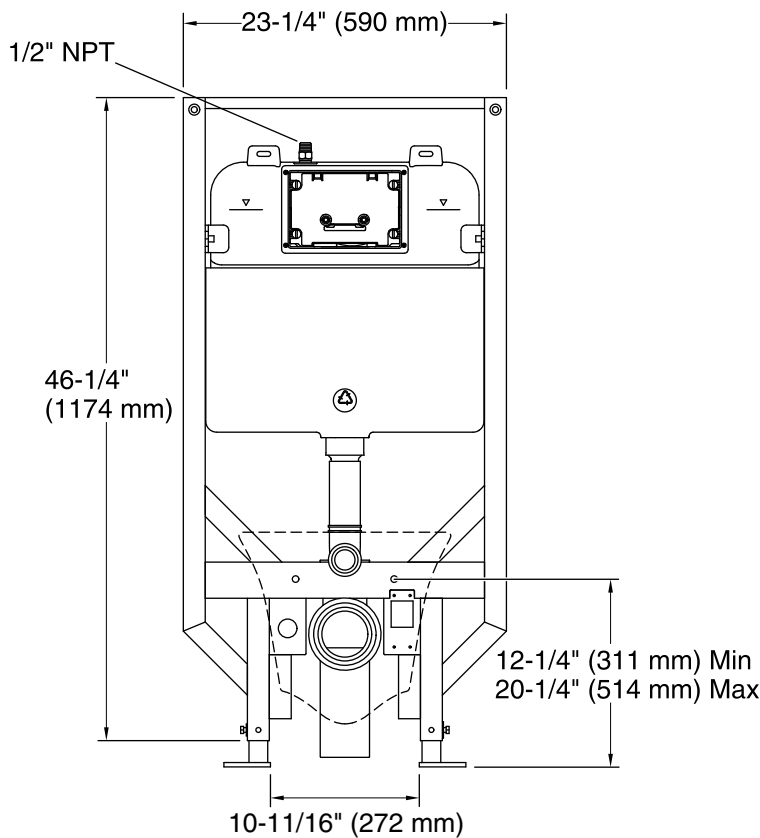

### Technical Information

All product dimensions are nominal.

Toilet type: In-wall, Wall-mount

Waste Outlet: Wall

Water Consumption

Full: 1.6 gpf (6 lpf)

Reduced: 0.8 gpf (3 lpf)

### Fixture Supply Requirements

Max static pressure: 80 psi (551.6 kPa)

### Notes

Install this product according to the installation instructions.

Requires 2x4 or 2x6 stud construction.

Refer to manufacturer and local codes for flush valve requirements.

In-wall tank and carrier system install in wall opening 3-3/16" (80 mm) x 23-1/4" (519 mm) x 50" (1270 mm) minimum.

Maximum inlet water temperature shall not exceed 80°F (26.7°C).