

QuickSetter+™ Low-lead balancing valve with flow meter

132 series



01283/19 NA

Replaces 01283/16 NA



Function

The QuickSetter+™ manual balancing valve contains a built-in flow meter and sight gauge, negating the need for differential pressure gauges and reference charts. Circuit balancing is fast, easy and accurate. Constructed of DZR low-lead brass, QuickSetter+ is ideally suited for use in plumbing applications such as hot water recirculation systems. The built-in check valve protects against circuit thermo-siphoning. The outlet temperature gauge (optional) verifies the fluid temperature in the circuit. The flow meter sight gauge is dry (not exposed to the fluid) thus eliminating the possibility of gauge clouding/scaling over time. The QuickSetter+ can also be used in heating systems.

Product range

132 series Balancing valve with flow meter, includes check valve and optional outlet temperature gauge.....sizes 1/2", 3/4", 1" with sweat, PEX crimp, PEX expansion union connections or size 3/4" with press union connections

Technical specifications

Materials

Valve

Body:	DZR low-lead brass
Ball:	stainless steel
Ball control stem:	brass, chrome plated
Ball seal seat:	PTFE
Control stem guide:	PSU
Seals:	peroxide-cured EPDM

Flow meter

Body and headwork:	DZR low-lead brass
Bypass valve stem:	stainless steel
Springs:	stainless steel
Seals:	peroxide-cured EPDM
Flow meter float and indicator cover:	PSU

NSF/ANSI 372-2011, Drinking Water System Components-Lead Content Reduction of Lead in Drinking Water Act, California Health and Safety Code 116875 S.3874, Reduction in Drinking Water Act, certified by ICC-ES, file PMG-1360.

Performance

Suitable Fluids:	water, glycol solutions
Max. percentage of glycol:	50%
Max. working pressure:	150 psi (10 bar)
Working temperature range:	14 - 230°F (-10-110°C)
Flow rate range unit of measurement:	1/2 - 1 3/4 gpm 2 - 7 gpm
Accuracy:	±10%
Control stem angle of rotation:	90°
Control stem adjustment wrench:	9 mm

Certifications

1. NSF/ANSI 372, Drinking Water System Components-Lead Content Reduction of Lead in Drinking Water Act, California Health and Safety Code 116875 S.3874, Reduction in Drinking Water Act, Vermont Act 193 - The Lead in Plumbing Supplies Law and Maryland's Lead Free Law HB.372, certified by ICC-ES, file PMG-1360.
2. PEX crimp fittings certified to ASTM F 1807.
3. PEX expansion fittings certified to ASTM F 1960.

Connections

Main connections: 1/2", 3/4", 1" sweat union
1/2", 3/4", 1" PEX crimp union
1/2", 3/4", 1" PEX expansion union
3/4" press union

Lay length (press connection): size 3/4 inch without gauge: 7 5/16" size 3/4 inch with gauge: 10 1/8"

Flow rate ranges

Without temperature gauge.

Code	Union Connections	Flow rate (gpm)	Fully open Cv
132434AFC	½" PEX crimp	0.5 - 1.75	1.0
132432AFC	½" PEX expansion	0.5 - 1.75	1.0
132439AFC	½" sweat	0.5 - 1.75	1.0
132534AFC	¾" PEX crimp	0.5 - 1.75	1.0
132532AFC	¾" PEX expansion	0.5 - 1.75	1.0
132536AFC	¾" press	0.5 - 1.75	1.0
132539AFC	¾" sweat	0.5 - 1.75	1.0
132634AFC	1" PEX crimp	0.5 - 1.75	1.0
132632AFC	1" PEX expansion	0.5 - 1.75	1.0
132639AFC	1" sweat	0.5 - 1.75	1.0
132454AFC	½" PEX crimp	2.0 - 7.0	6.3
132452AFC	½" PEX expansion	2.0 - 7.0	6.3
132459AFC	½" sweat	2.0 - 7.0	6.3
132554AFC	¾" PEX crimp	2.0 - 7.0	6.3
132552AFC	¾" PEX expansion	2.0 - 7.0	6.3
132556AFC	¾" press	2.0 - 7.0	6.3
132559AFC	¾" sweat	2.0 - 7.0	6.3
132654AFC	1" PEX crimp	2.0 - 7.0	6.3
132652AFC	1" PEX expansion	2.0 - 7.0	6.3
132659AFC	1" sweat	2.0 - 7.0	6.3

With temperature gauge.

Code	Connection	Flow rate (gpm)	Fully open Cv
132435AFC	½" PEX crimp	0.5 - 1.75	1.0
132433AFC	½" PEX expansion	0.5 - 1.75	1.0
132438AFC	½" sweat	0.5 - 1.75	1.0
132535AFC	¾" PEX crimp	0.5 - 1.75	1.0
132533AFC	¾" PEX expansion	0.5 - 1.75	1.0
132537AFC	¾" press	0.5 - 1.75	1.0
132538AFC	¾" sweat	0.5 - 1.75	1.0
132635AFC	1" PEX crimp	0.5 - 1.75	1.0
132633AFC	1" PEX expansion	0.5 - 1.75	1.0
132638AFC	1" sweat	0.5 - 1.75	1.0
132455AFC	½" PEX crimp	2.0 - 7.0	6.3
132453AFC	½" PEX expansion	2.0 - 7.0	6.3
132458AFC	½" sweat	2.0 - 7.0	6.3
132555AFC	¾" PEX crimp	2.0 - 7.0	6.3
132553AFC	¾" PEX expansion	2.0 - 7.0	6.3
132557AFC	¾" press	2.0 - 7.0	6.3
132558AFC	¾" sweat	2.0 - 7.0	6.3
132655AFC	1" PEX crimp	2.0 - 7.0	6.3
132653AFC	1" PEX expansion	2.0 - 7.0	6.3
132658AFC	1" sweat	2.0 - 7.0	6.3

Dimensions

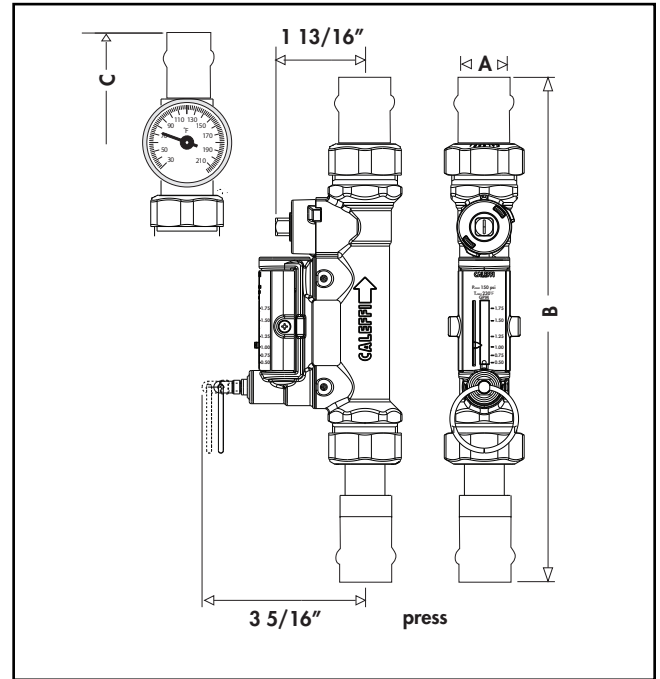
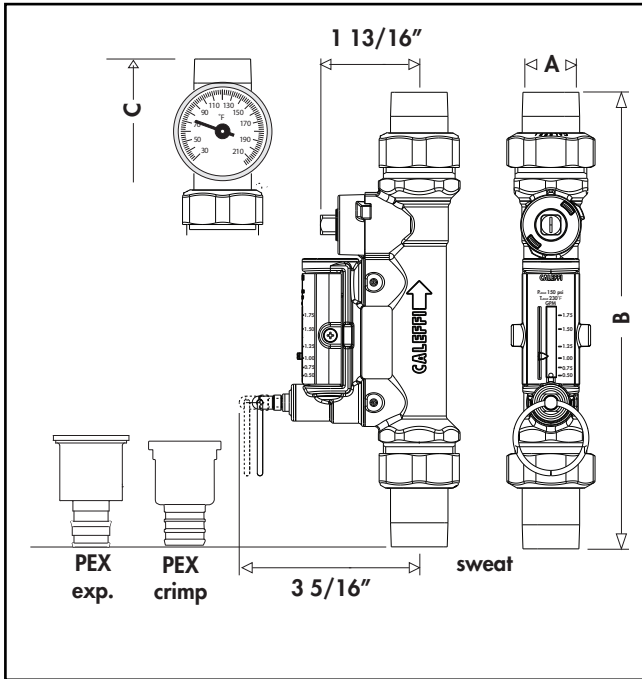

Code (w/o gauge)	Code (w/ gauge)	A	B (w/o gauge)	C (w/ gauge)	Wt (lb)*
132434AFC	132435AFC	1/2" PEX crimp	9"	10 5/16"	1.8/2.2
132432AFC	132433AFC	1/2" PEX expansion	9 1/8"	10 7/16"	1.8/2.2
132439AFC	132438AFC	1/2" sweat	8 3/8"	9 11/16"	2.0/2.4
132534AFC	132535AFC	3/4" PEX crimp	10 1/8"	12 5/8"	2.0/2.4
132532AFC	132533AFC	3/4" PEX expansion	10 7/8"	13 3/8"	2.0/2.4
132539AFC	132538AFC	3/4" sweat	8 7/16"	9 13/16"	1.8/2.2
132634AFC	132635AFC	1" PEX crimp	8 11/16"	10 1/4"	2.2/2.6
132632AFC	132633AFC	1" PEX expansion	9 11/16"	11 1/4"	2.2/2.6
132639AFC	132638AFC	1" sweat	8 9/16"	10 1/8"	2.4/2.8
132454AFC	132455AFC	1/2" PEX crimp	9"	10 5/16"	1.8/2.2
132452AFC	132453AFC	1/2" PEX expansion	9 1/8"	10 7/16"	1.8/2.2
132459AFC	132458AFC	1/2" sweat	8 3/8"	9 11/16"	2.0/2.4
132554AFC	132555AFC	3/4" PEX crimp	10 1/8"	12 5/8"	2.0/2.4
132552AFC	132553AFC	3/4" PEX expansion	10 7/8"	13 3/8"	2.0/2.4
132559AFC	132558AFC	3/4" sweat	8 7/16"	9 13/16"	1.8/2.2
132654AFC	132655AFC	1" PEX crimp	8 11/16"	10 1/4"	2.2/2.6
132652AFC	132653AFC	1" PEX expansion	9 11/16"	11 1/4"	2.2/2.6
132659AFC	132658AFC	1" sweat	8 9/16"	10 1/8"	2.4/2.8

*(without temperature gauge / with temperature gauge)

Code (w/o gauge)	Code (w/ gauge)	A	B (w/o gauge)	C (w/ gauge)	Wt (lb)*
132536AFC	132537AFC	3/4" press	9 7/8"	12 1/8"	1.8/2.2
132556AFC	132557AFC	3/4" press	9 7/8"	12 1/8"	1.8/2.2

*(without temperature gauge / with temperature gauge)

Operating principle

The balancing valve is a hydraulic device that controls flow rate. The control mechanism is a ball valve (1), operated by a control stem (2). The flow rate is manually and properly set by use of the convenient onboard flow meter (3) housed in a bypass circuit on the valve body. This circuit is automatically shut off during normal operation. The flow rate is indicated by a metal ball (4) sliding inside a transparent channel (5) with an integral graduated scale (6). The QuickSetter+ also includes an inlet check valve (7) to prevent reverse flow.

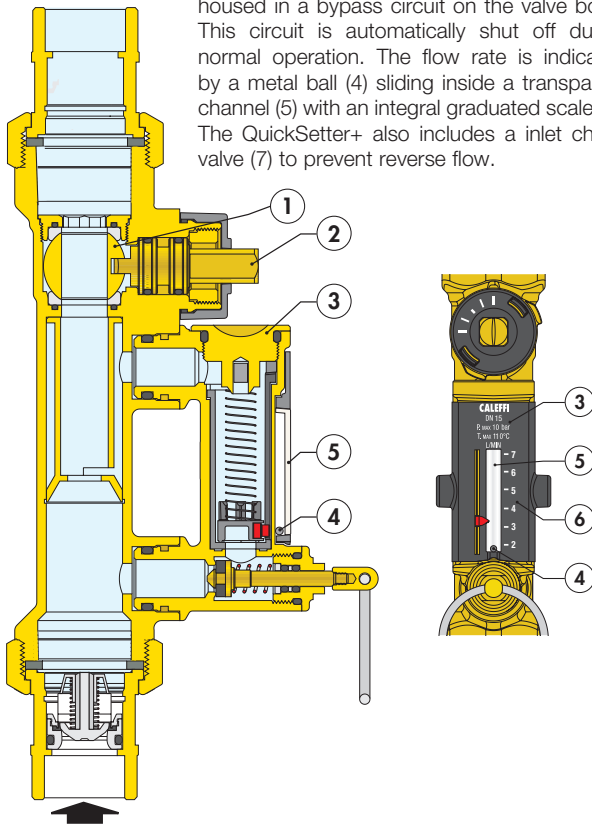

Hydraulic characteristics at 100% open

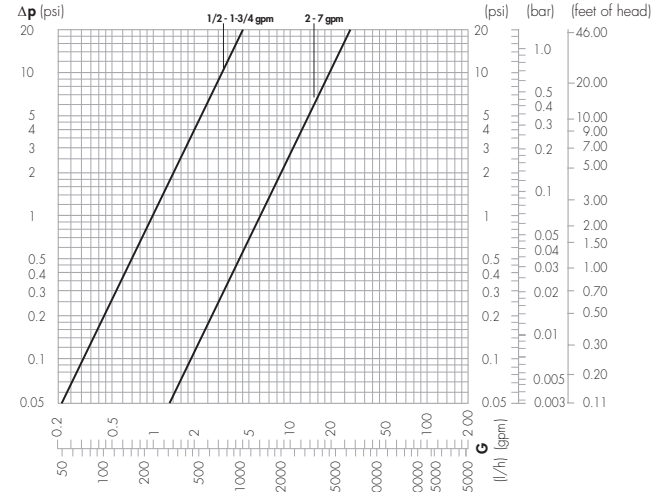

Connection	Flow rate (gpm)	Fully open Cv
1/2" sweat, PEX crimp & expansion	0.5 - 1.75	1.0
3/4" sweat, PEX crimp & expansion, press	0.5 - 1.75	1.0
1" sweat, PEX crimp & expansion	0.5 - 1.75	1.0
1/2" sweat, PEX crimp & expansion	2.0 - 7.0	6.3
3/4" sweat, PEX crimp & expansion, press	2.0 - 7.0	6.3
1" sweat, PEX crimp & expansion	2.0 - 7.0	6.3

Construction details

Flow meter

When activated by pulling the operating ring (2), the flow rate is indicated on the flow meter housed in a bypass circuit on the valve body. When finished reading the flow rate, the flow meter is automatically shut off, isolating it during normal operation. Use of a flow meter greatly simplifies the process of system balancing since the flow rate can be measured and controlled at any time without differential pressure gauges or reference charts. The onboard flow meter eliminates the need to calculate valve settings during system setup. Additionally, the unique onboard flow meter offers unprecedented time and cost savings by eliminating the long and difficult procedure of calculating pre-settings associated with using traditional balancing devices.

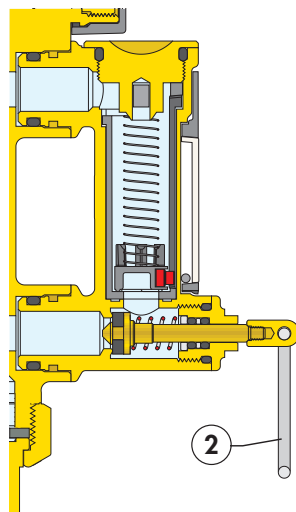

Flow meter bypass valve

The bypass valve (1) opens and closes the circuit between the flow meter and the valve. The bypass valve is easily opened by pulling the operating ring (2), and is automatically closed by the internal return spring (3) when finished reading the flow rate. The spring and the EPDM seal (4) provide a reliable seal to isolate the flow meter during normal operation.

The operating ring (2) material has low thermal conductivity to avoid burns if the flow meter is opened while hot fluid is passing through the valve.

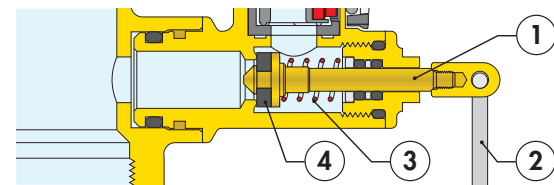

Ball/magnet indicator

The metal ball (4) that indicates the flow rate is not in direct contact with the fluid passing through the flow meter.

This is an effective and innovative measuring system in which the ball slides up and down inside a transparent channel (5) that is isolated from the fluid flowing through the body of the flow meter. The ball is moved by a magnet (6) connected to a float (7). In this way the flow rate indication system **remains perfectly clean and provides reliable readings over time.**

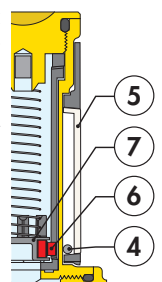

Complete closing and opening of the valve

The valve can be completely closed and opened. A slot on the control stem indicates the valve position. When the control stem is turned fully clockwise (the slot is perpendicular to the axis of the valve), the valve is fully closed (A). When the control stem is turned fully counter-clockwise (the slot is parallel to the axis of the valve), the valve is fully open (B).

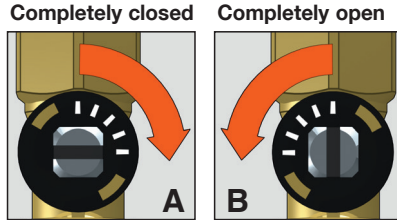

Installation

Install the balancing valve in a location that ensures free access to the flow meter shutoff valve, control stem and flow rate indicator. To ensure accurate flow measurement, straight sections of pipe installed as shown is recommended.

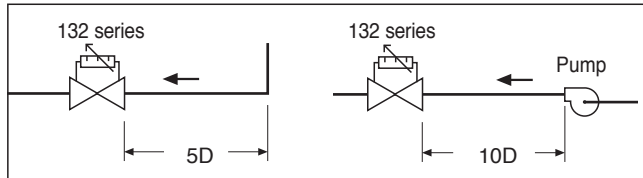

The valve can be installed in any position with respect to the flow direction shown on the valve body. Additionally, the valve can be installed either horizontally or vertically.

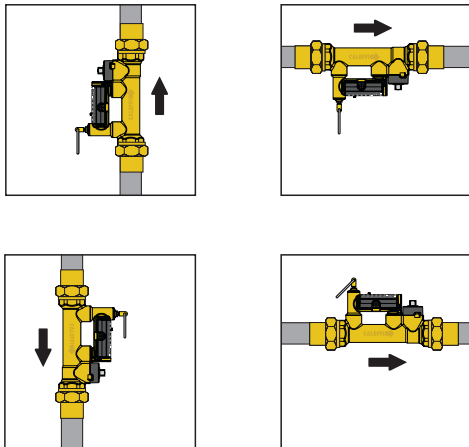

Flow rate adjustment

The flow rate is adjusted as follows:

- A. With the aid of the flow rate indicator (1), mark the desired flow rate.
- B. Use the operating ring (2) to open the bypass valve slowly. This allows fluid to flow through the flow meter (3). The bypass valve is automatically closed under normal operating conditions.

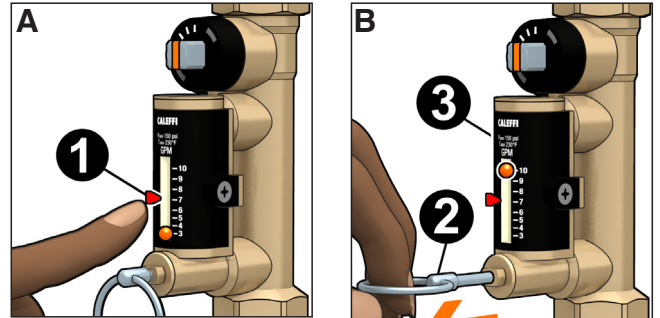

- C. While holding the bypass valve open, use a wrench to turn the valve control stem (4) to adjust the flow rate slowly. The resulting flow rate is indicated by the metal ball (5) that slides up and down inside a transparent channel (6) marked by a graduated scale in gpm.

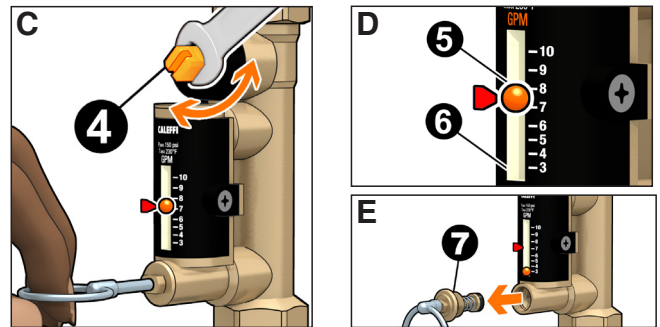

- D. Once the flow rate is properly adjusted, release the operating ring (2) of the bypass valve. The valve will automatically return to the closed position by means of an internal spring.
- E. A replacement bypass valve stem (7) with operating ring is available in event it is damaged and inoperable. Order code F19346.

Hot water recirculation

Balanced example

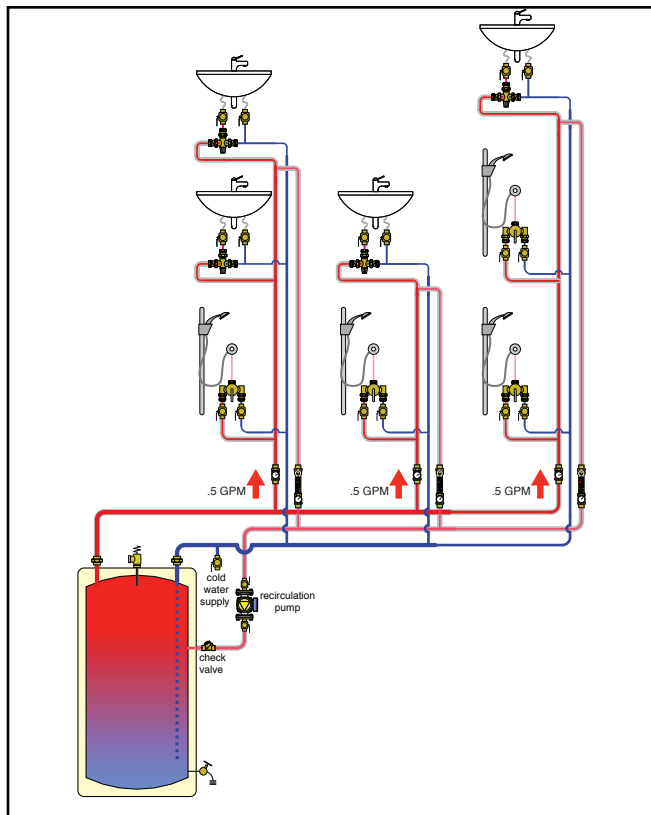

Unbalanced example

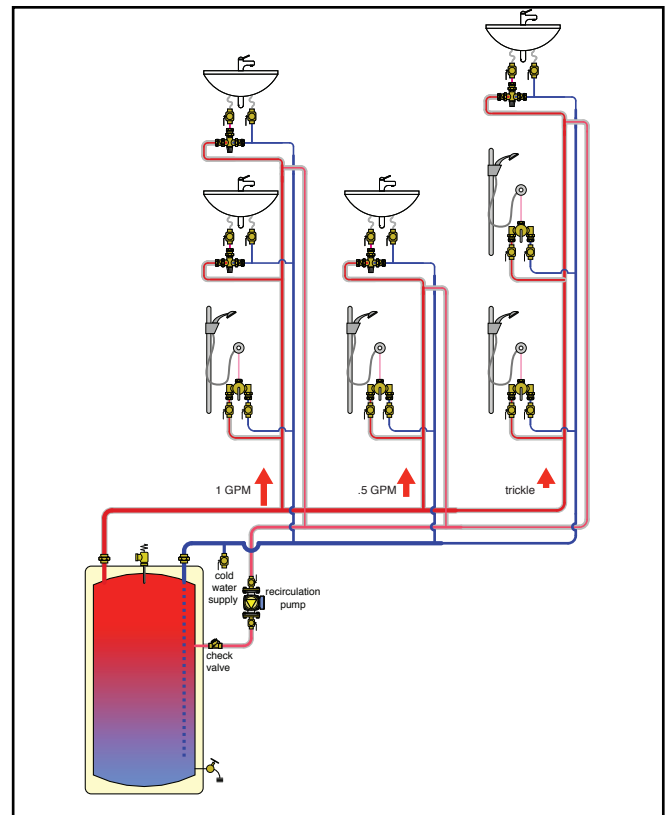

Balancing made fast, easy, and accurate with QuickSetter+

Hot water recirculation systems are designed to minimize wait time for hot water to arrive when a fixture is opened. Systems left unbalanced or improperly balanced result in wasted water down the drain, a costly and environmentally unfriendly situation - not to mention the undesired annoyance placed on building occupants. The QuickSetter+ takes the guess work and labor out of balancing. With the valve's exclusively designed venturi mechanism, the installer simply pulls the flow indicator by-pass pin, adjusts the flow to the desired flow rate while viewing the built-in sight gauge, and releases the pin. Easy, accurate balancing in seconds. No instruments or reference graphs are needed.

NOTES



Replacement body.
Select fittings from the Catalog Product Guide, fitting section.



QuickSetter Insulation sleeve for valve and fitting on each end.

Code	Description	Lbs
132637	0.5 to 1.75 gpm	1.0
132657	2.0 to 7.0 gpm	1.0

Code	Description	Lbs
F0000926	For models with temperature gauge	0.1
112001	For models without temperature gauge	0.1



Replacement flow meter.

Code	Description	Lbs
F0000940	0.5 to 1.75 gpm	0.2
F0000941	2.0 to 7.0 gpm	0.2

SPECIFICATION SUMMARY

132 series

Balancing valve with flow meter. Sweat, PEX crimp and PEX expansion union connections 1/2", 3/4", 1". PEX crimp fittings must comply with ASTM F 1807. PEX expansion fittings must comply with ASTM F 1960. Press union connection 3/4". DZR low-lead brass body (<0.25% Lead content) certified by ICC-ES file PMG-1360. Stainless steel ball. Chrome-plated brass ball control stem. PTFE ball seal seat. PSU control stem guide. DZR low-lead brass flow meter body and headwork. Stainless steel flow meter bypass valve stem. Stainless steel flow meter springs. PSU flow meter float and indicator cover. Peroxide-cured EPDM seals. Provided with inlet flow check valve. Water and glycol solutions. Maximum percentage of glycol 50%. Maximum working pressure 150 psi (10 bar). Working temperature range 14 to 230 degrees F (-10 to 110 degrees C). Flow rate range unit of measurement gallons per minute (gpm). Accuracy ± 10%. Control stem angle of rotation 90°. Provide with optional mixed outlet temperature gauge, 30 to 210 degree F scale, 2 inch diameter.

We reserve the right to change our products and their relevant technical data, contained in this publication, at any time and without prior notice.



Caleffi North America, Inc.
3883 W. Milwaukee Road
Milwaukee, WI 53208
Tel: 414-238-2360 · Fax: 414-238-2366
sales@caleffi.com · www.caleffi.com
© Copyright 2019 Caleffi North America, Inc.