

## **⚠ WARNING**

**DISCONNECT POWER BEFORE RE-LAMPING OR WIRING THE FIXTURE  
READ ALL INSTRUCTIONS COMPLETELY BEFORE STARTING INSTALLATION.**

## **⚠ CAUTION**

- TO AVOID THE RISK OF FIRE OR SHOCK, FIXTURE MUST BE INSTALLED IN COMPLIANCE WITH ALL APPLICABLE NATIONAL AND LOCAL ELECTRICAL/BUILDING CODES.
- INSTALLATION AND MAINTENANCE OF THIS UNIT REQUIRES AN ELECTRICIAN OR CERTIFIED FACTORY TRAINED TECHNICIAN.
- If an existing fixture is being replaced, remove it and note to which of the wires in the outlet box the fixture was attached. DO NOT SEPARATE ANY OTHER WIRES THAT MAY BE IN THE BOX. DO NOT DAMAGE THE INSULATION OF OLDER WIRING. In regular circumstances the BLACK wire will be the "Hot" lead and the WHITE wire will be the "Neutral" or "Common" lead A GREEN or BARE COPPER wire is the "Ground". In older buildings it is always good practice to reconfirm the polarity of the wiring.

## **NOTICE**

- The important safeguards and instructions outlined on this sheet cannot cover all possible conditions and situations that may occur. It must be understood that common sense, caution and care factors that cannot be built into any product. Caution and care must be supplied by the person(s) installing, operating and caring of this lighting fixture.
- This fixture is designed to be mounted on a correctly installed standard round or octagon box or a through wiring box with a plaster frame. The box must be securely mounted to the structure of the building. The crossbar and hardware supplied should be used. Directly mounting the fixture to the outlet box may make it impossible to correctly align the fixture.

## **NOTICE:**

**CALIFORNIA PROP 65: THIS LIGHTING FIXTURE CONTAINS CHEMICALS KNOWN TO THE STATE OF CALIFORNIA TO CAUSE CANCER, BIRTH DEFECTS, AND/OR OTHER REPRODUCTIVE HARM. WASH HANDS AFTER USE.**

### **FIXTURE PREPARATION**

1. Remove the fixture, parts and parts bag(s) from the carton.

#### **NOTICE:**

- Before discarding the carton, double check to make certain that all parts are found.

### **FIXTURE INSTALLATION**

1. Attach the mounting ring with wings to the outlet box.  
(The green screw should face out).  
The wings should be oriented vertically.
2. Fasten the ground wire to the green or bare copper wire in the outlet box of the green screw on the mounting ring with wings.

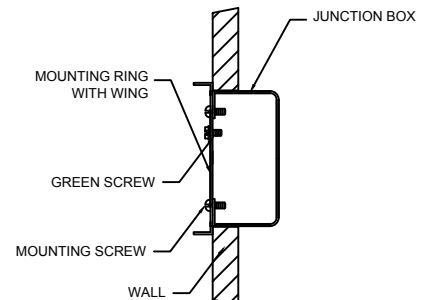

## **⚠ WARNING**

**Never fasten the ground wire to the black or "hot" wire!  
Failure to follow this instruction could result in serious injury or death!**

**FIGURE-01**

- Fasten the white fixture lead to the white wire in the outlet box.  
Fasten the wires together with an approved fastener (wire nut). Starting about 1" below the fastener, tightly wrap the connection with electrical tape so that the connections seals the end of the fastener.

**⚠ WARNING**  
Make sure that there is no exposed wire or strands that could cause a dangerous short circuit!

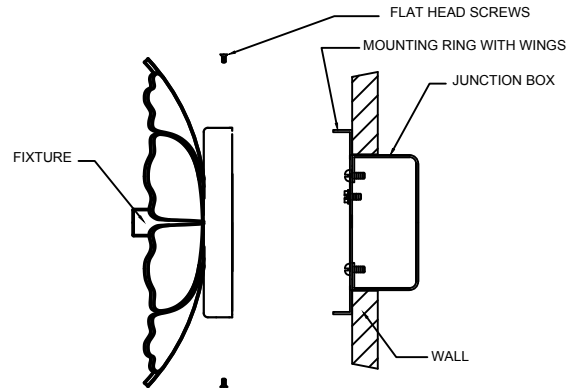
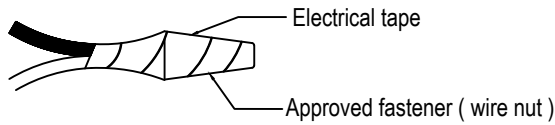

FIGURE-02

- Connect the black fixture lead to the black wire in the outlet box. Fasten the joined wires as in step 3.
- Attach the fixture to the mounting ring with wings and secure it with flathead screws.  
(See Figure-02)
- Install the lamps. (type-G9 lamp)

**NOTICE:**  
This fixture is rated for 20w G9 lamp.

**NOTE:**  
(This fixture includes G9 bulb.)

**⚠ WARNING**  
DO NOT EXCEED RECOMMENDED WATTAGE!

- Install the glass ball diffuser and accent flower. Insert the accent flower to the flower on the frame then secure it with the glass ball with fitter. (See Figure-03).
- Restore power to the circuit breaker or fuse box.

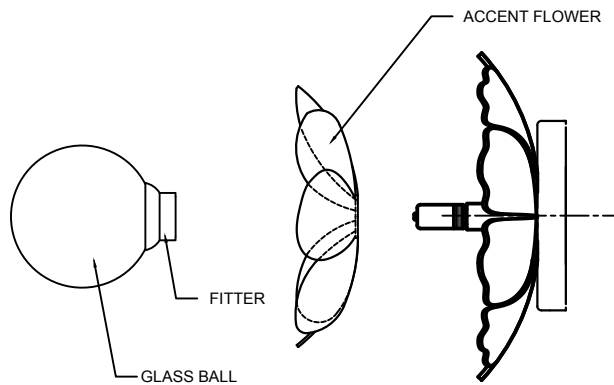

FIGURE-03