

**! WARNING**

**DISCONNECT POWER BEFORE RE-LAMPING OR WIRING THE FIXTURE  
READ ALL INSTRUCTIONS COMPLETELY BEFORE STARTING INSTALLATION.**

**! CAUTION**

- TO AVOID THE RISK OF FIRE OR SHOCK, FIXTURE MUST BE INSTALLED IN COMPLIANCE WITH ALL APPLICABLE NATIONAL AND LOCAL ELECTRICAL/BUILDING CODES.
- INSTALLATION AND MAINTENANCE OF THIS UNIT REQUIRES AN ELECTRICIAN OR CERTIFIED FACTORY TRAINED TECHNICIAN.
- If an existing fixture is being replaced, remove it and note to which of the wires in the outlet box the fixture was attached. DO NOT SEPARATE ANY OTHER WIRES THAT MAY BE IN THE BOX. DO NOT DAMAGE THE INSULATION OF OLDER WIRING. In regular circumstances the BLACK wire will be the "Hot" lead and the WHITE wire will be the "Neutral" or "Common" lead A GREEN or BARE COPPER wire is the "Ground". In older buildings it is always good practice to reconfirm the polarity of the wiring.

**NOTICE**

- The important safeguards and instructions outlined on this sheet cannot cover all possible conditions and situations that may occur. it must be understood that common sense, caution and care factors that cannot be built into any product. Caution and care must be supplied by the person(s) installing, operating and caring of this lighting fixture.
- This fixture is designed to be mounted on a correctly installed standard round or octagon box or a through wiring box with a plaster frame. The box must be securely mounted to the structure of the building. The crossbar and hardware supplied should be used. directly mounting the fixture to the outlet box may make it impossible to correctly align the fixture.

**FIXTURE PREPARATION**

1. Remove the fixture, glass/metal prism, parts and parts bag(s) from the carton.

**NOTICE:**  
Before discarding the carton,  
double check to make certain that all parts are found .

**FIXTURE INSTALLATION**

1. Attach the mounting ring to the outlet box.  
(the green screw should face out).
2. Fasten the ground wire to the green or bare copper wire in the outlet box or the green screw on the mounting ring.

**! WARNING**

**Never fasten the ground wire to the black or "hot" wire!  
Failure to follow this instruction could result in  
serious injury or death!**

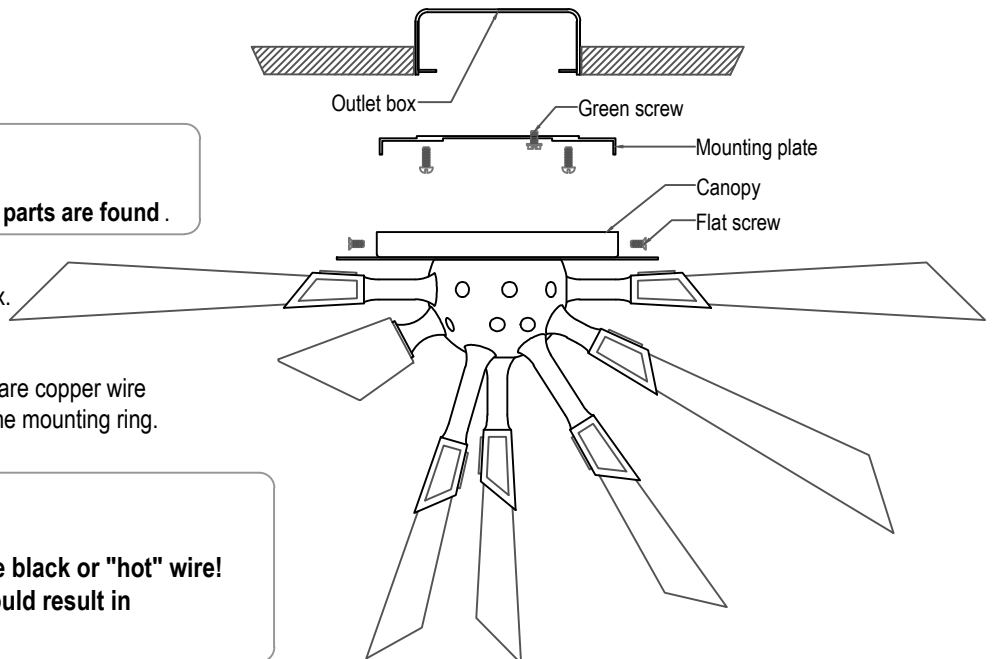

**FIGURE-1**

3. Fasten the white fixture lead to the white wire in the outlet box.  
Fasten the wires together with an approved fastener (wire nut).  
Starting about 1" below the fastener, tightly wrap the connection with electrical tape so that the connections seals the end of the fastener.



### **WARNING**

**Make sure that there is no exposed wire or strands that could cause a dangerous short circuit!**

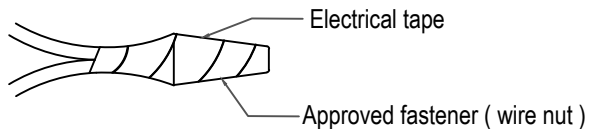

4. Connect the black fixture lead to the black wire in the outlet box.  
Fasten the joined wires as in step 3.
5. Using the flat screws, loosely fasten the fixture to the mounting plate.  
Rotate and align the canopy as necessary .Tighten the flat screws.
6. Place the glass (See figure-2) using the special tool supplied.

**NOTICE:  
DO NOT OVER TIGHTEN THE CAP RING!**

7. Install the lamps (G9 lighting bulbs). NOTE: This fixture is rated for 50 watts G9 lamp.



**WARNING  
DO NOT EXCEED RECOMMENDED WATTAGE!**

8. Thread the glass/metal prism to the distributor,  
Following the prism schedule given (See figure-2 & 3).

**NOTICE:  
HOLD THE METAL PART WHEN THREADING!**

9. Restore power to circuit at breaker or fuse box.

**FIGURE-2**

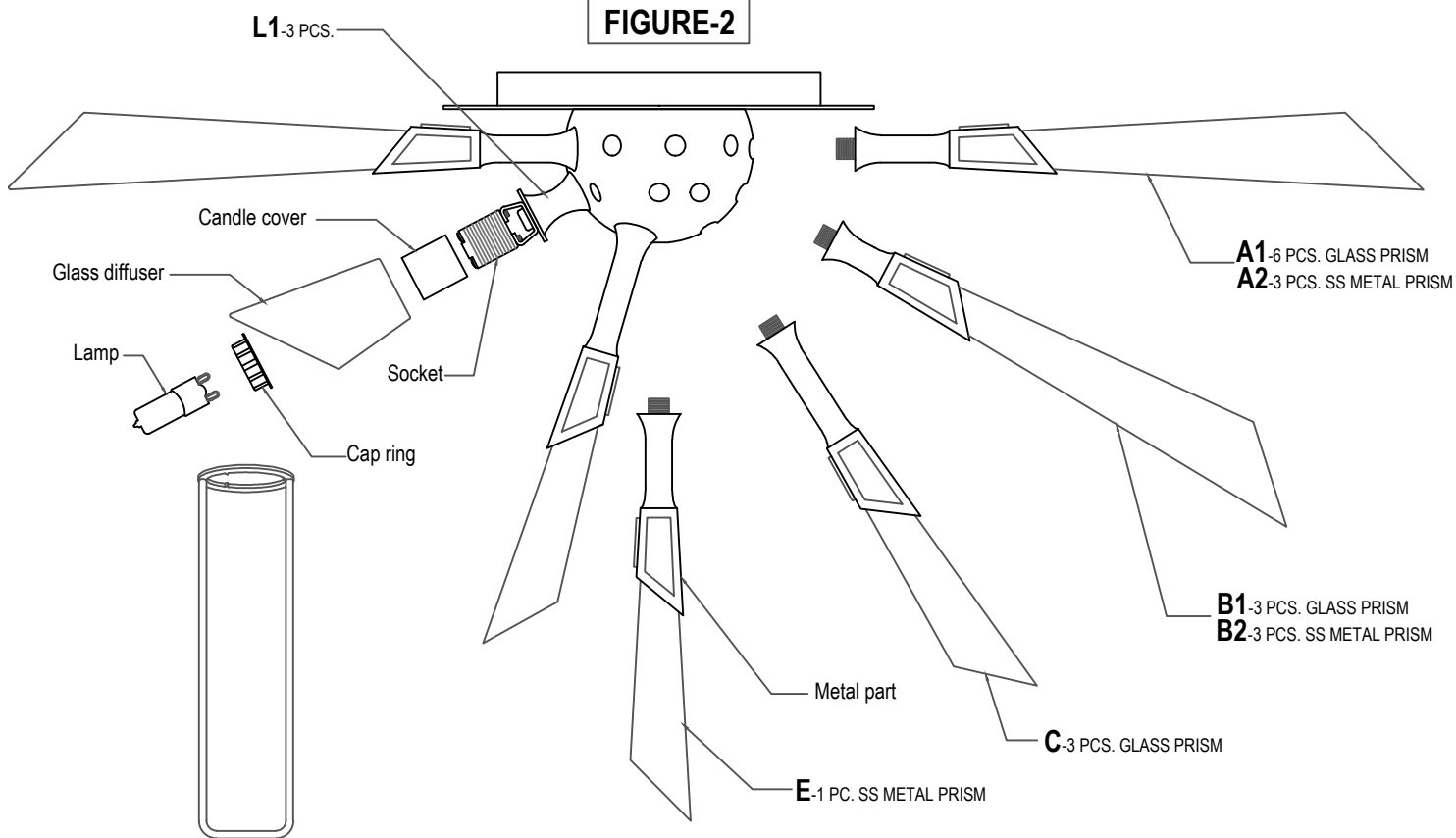

**SPECIAL TOOL**

**PRISM SCHEDULE**

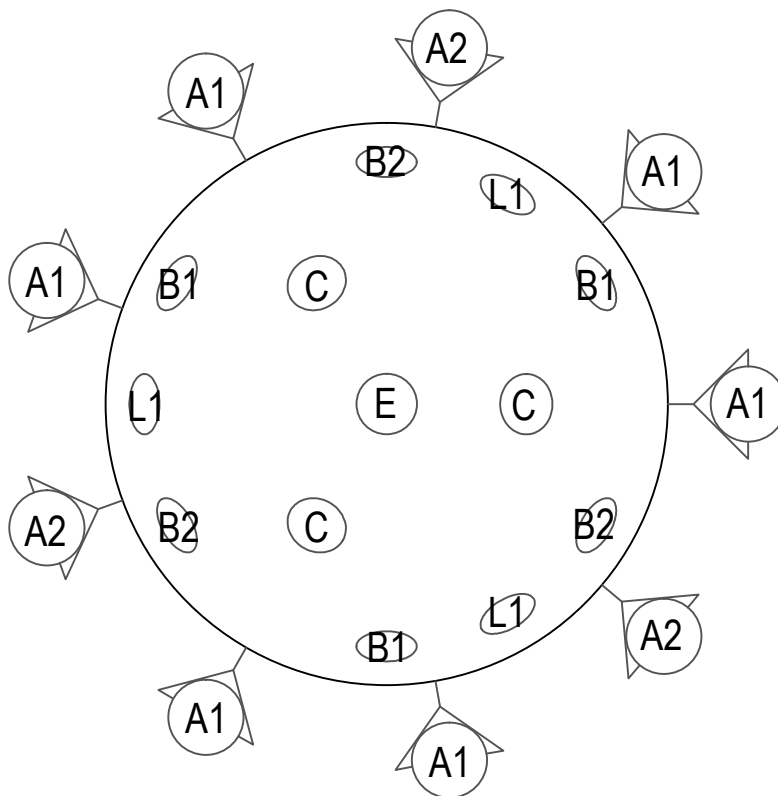

**BOTTOM VIEW**

**FIGURE-3**